



# SAFETY EYEWEAR

planning your protection





**X-GENERATION**



**SPECTACLES**

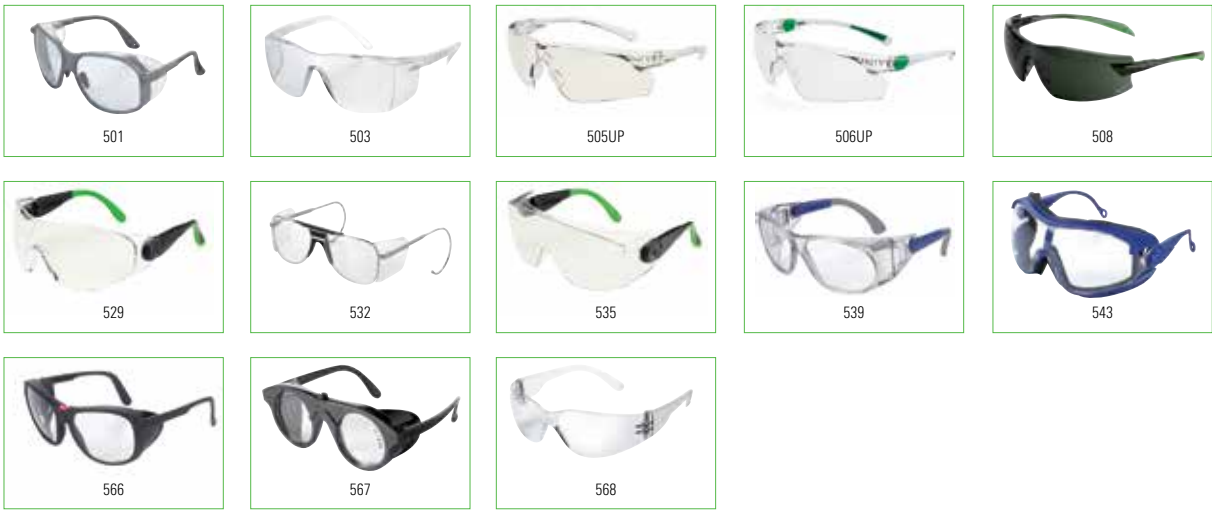

**PRESCRIPTION**



**GOGGLES**



**FACE SHIELDS**



**WELDING - IR**



# Green is Univet



5X9



6X1



6X3



511



513



516



519



520



528



546



549



551



553 ZERONOISE



554



557



536.07



536.08



539



541



552



611 CLEAN ROOM



619



619 CLEAN ROOM



620



540



566



567



601



603

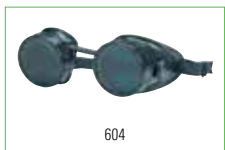

604

# Univet Optical Technologies - Research and development

The strength of Univet resides in our particularly active and brilliant Research and Development Department. This is due to Univet's investment in advanced analysing technologies and highly competent and experienced personnel.

Univet's style and philosophy are shown throughout the product range, by our strong commitment of innovation and high quality of production.

The style and work ethic characterized by all the Univet Team, in Italy and world markets, along with of the most advanced research instrumentation provides the basis for our Highly innovative and stylish products, providing our customers excellent safety and comfort mixed with Italian elegance and style.



Glassworks



Metal working



Clean room



LED industry

## ARLab

APPLIED RESEARCH LABORATORY

The philosophy of Univet is based on developing exclusive products with constant and proven quality. To achieve and maintain this goal, the company has been equipping itself with specific equipment to be able to do testing according to the standards required on the protection devices. Univet's laboratory, with its advanced equipment, is capable of performing preliminary tests during the design phase, certification testing for the main European and non-European standards as well as periodic examinations of samples of all products. The high level of technological equipment coupled with the presence of qualified personnel allows Univet to provide concrete support to the development of new products and to enable the establishment of quality control procedures that exactly replicate the certification testing required by the product.

Thanks to the laboratory together with rapid prototyping and reverse engineering equipment, Univet is also able to do tests directly on internally developed prototypes and make any necessary changes in a very short time.

## Special applications

The direct contact with customers, allows a constant monitoring of market requirements, thus fuelling the dynamism and desire of our R&D department to satisfy every application with products either from the catalogue or full development of new products.

Univet can respond to specific requests, and particular risks to which workers are exposed, and analysed these risks, in order to develop products that fill gaps in the market, thus offering protection in usually unexplored areas.



# NEXXT

Higher technological innovation applied to the protection of the eyes and an in-depth study of design characterise Univet **nEXxt** project: a family of products that anticipates the needs of the market by bringing the concept of protection to a new level.

In the workplace the interaction between different PPE often not developed for being used in conjunction leads to a loss in protective capability that forces the user to operate in conditions of lower security.

**nEXxt** range is designed by carefully analysing the geometry of the eyewear based on the possible interaction with other PPE to ensure the best possible protection to the worker and total comfort. The use of special engineering devices, in addition to the possibility of an independent use, enables products to harmonise perfectly with other safety devices.



## 553 - ZERONoise

The effectiveness of hearing protection may be compromised due to the bulkiness of the temples of optical protective devices. The innovative 553ZERONoise model equipped with patented temples specially designed to facilitate the combined use of the two protective devices.

The geometry has been carefully studied: the shorter terminals and the reduced sections cancel the interference with cushions avoiding the ear muff loses part of its attenuation capacity. The flexible and shaped temples give the operator comfort, and allow to wear the glasses without having to remove the ear muffs.



## 6X3 - Next generation Goggle

6X3 is designed to provide extended protection by combining the top features of protective goggles to new specifications for performance never reached before.

The originality of the device is expressed in the design of the facial support that ensures a proper seating for respiratory masks and half masks and in the use of additional facial protection that provides total protection to the operator's face.

The possibility of wearing corrective glasses, the exclusive UDC coating, the interchangeable lens offer great versatility by allowing the use of this device in multiple applications with no compromise to safety and comfort.



# Univet Optical Technologies - Applied optical technology

The research shows that different facial features require a custom fit. The presence of adjustable nosepad and temples in length and inclination allow to adapt the device to the face of each user for optimum comfort in every situation.



## SOFTPAD - Technology comfort

Through the many settings of the terminal, the innovative use of materials and a meticulous design of SoftPad refines the already impressive ergonomics of Univet models, reaching a new and absolute comfort. SoftPad technology is a patented system designed to provide perfect stability to the safety glasses and full adaptability to the face of the user. The support of the eyewear is entrusted to the whole support area of the arm for a comfortable and stable fit. In addition to the length adjustment in 3 positions, the SoftPad system has a further tilting movement that allows the device to fit perfectly to the user's head.

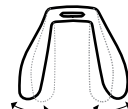
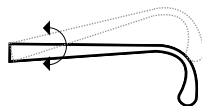
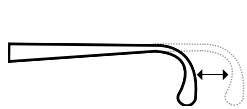

## TEMPLES

The temples adjustable in length and inclination allow to get the highest level of protection by combining the performance of the eyewear with a perfect fit. Each user is able to find the perfect device configuration and work in constant safety.

## NOSE PAD

An adjustable nosepad allows to adapt the height of the model, in order to view through the middle section of the lens where it is assured the highest optical quality. Fitting and visual comfort are therefore guaranteed for long periods, avoiding eye strain.

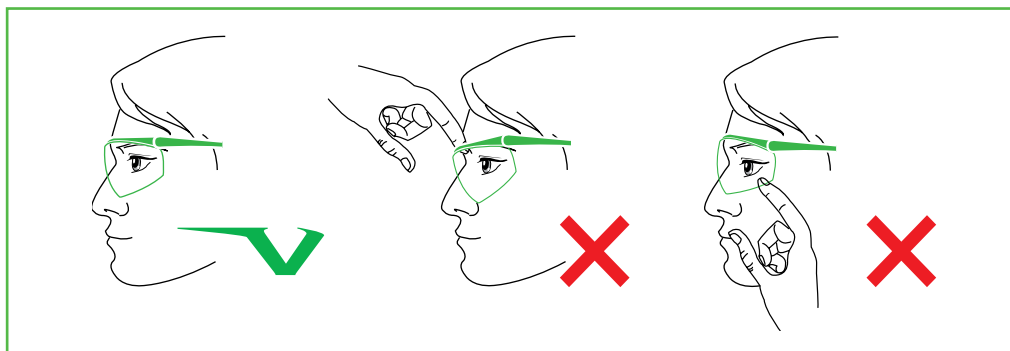

## UDC - Univet advanced Double Coating

The breakthrough UDC technology provides to the spectacle superior resistance against scratching (outer surface) and fogging (inside surface). The treatments applied in separate processes are permanent and provide exceptional performance in any working condition.

This technology is expressed in 5X3 UDC, 6X3 UDC and 620 UDC models, symbols of Univet philosophy, combining style, comfort and innovation.



## ANTI-FOG PLUS

The Anti-fog Plus treatment is a film of the thickness of a few  $\mu\text{m}$  deposited on the entire surface of the lens, which, due to its chemical and physical abilities, prevents the formation of condensation by absorbing the humidity drops. This technology prevents the fogging of the PPE to allow the safe handling of the job by enabling a clear view even in critical environments.

The Anti-Fog Plus coating is permanent and it offers superior performance compared to the standards required by EN166 safety regulation.



## ANTI-SCRATCH PLUS

The Anti-Scratch Plus is a treatment applied to the surface of the lens whose hardness is a barrier against superficial damages that can impair vision. Univet lenses are therefore protected from scratches and abrasions caused by rubbing with solid particulate subsequent the use in dusty environments or cleaning operations.

Univet Anti-scratch Plus treatment achieves better performance than that specified by EN166 safety European standard.

# European Standards Personal Protective Equipment

Personal Protective Equipment (PPE) shall mean any device or appliance designed to be worn or held by an individual for protection against one or more health and safety hazards, as well as any accessory or ensemble designed to protect an individual.

The Personal Protective Equipment (PPE) are divided into three categories:



The standard EN166 recalls some of the other regulations that help define the requirements that the PPE must meet:

SPECTACLE

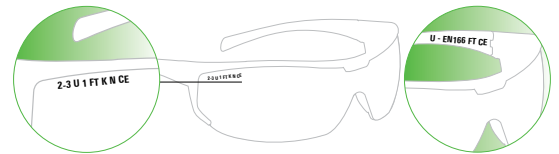

## LENS MARKING IDENTIFICATION

<b>2-3</b>	<b>U</b>	<b>1</b>	<b>FT</b>	<b>KN</b>	<b>CE</b>
Scale number (code number + shade number)	Manufacturer	Optical Class	Mechanical resistance	Optional requirement	

## FRAME MARKING IDENTIFICATION

<b>U</b>	<b>EN166</b>	<b>FT</b>	<b>CE</b>
Manufacturer	Standard	Mechanical resistance	

GOGGLE

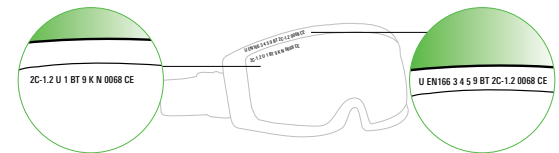

## LENS MARKING IDENTIFICATION

<b>2C-1.2</b>	<b>U</b>	<b>1</b>	<b>BT</b>	<b>9</b>	<b>KN</b>	<b>0068</b>	<b>CE</b>
Scale number (code number + shade number)	Manufacturer	Optical Class	Mechanical resistance	Field of use	Optional requirement	Notified body	

## FRAME MARKING IDENTIFICATION

<b>U</b>	<b>EN166</b>	<b>3 4 5 9</b>	<b>BT</b>	<b>2C-1.2</b>	<b>0068</b>	<b>CE</b>
Manufacturer	Standard	Field of use	Mechanical resistance	Highest scale number allowed	Notified body	



# Meanings of the EN marking

PPE of II° and III° categories shall be tested and certified by an official Notified Body.

The product certification which confirms the compliance to the requirements included in the PPE directive 89/686/EEC is based on the following European standards:

**EN166** – Personal eye-protection specifications

**EN175** – Equipment for eye and face protection during welding and allied processes

EN166 recalls additional standards which specifies the requirements as a function of PPE typology and field of use:

**EN165** – Vocabulary

**EN167** – Optical test methods

**EN168** – Non-optical test methods

**EN169** – Filter for welding and related techniques

**EN170** – Ultra-violet (UV) ray filters

**EN171** – Infra-red (IR) ray filters

**EN172** – Sunglare filters for industrial use

**EN1731** – Mesh eye and face protectors

**EN 379** – Specification for automatic welding filters

## SCALE NUMBER

Code Number		Shade number and typical lens colours		VLT range
<b>none</b>	Welding	<b>1.2</b>	Clear	100% - 74.4%
<b>2</b>	Ultraviolet (UV)	<b>1.7</b>	In/Out, yellow, clear mirrored, UVR	58.1% - 43.2%
<b>2C o 3</b>	UV with good colour recognition	<b>2.5</b>	Brown, smoke	29.1% - 17.8%
<b>4</b>	Infra-red (IR)	<b>3.1</b>	G15, smoke mirrored	17.8% - 8.0%
<b>5</b>	Sunglare filter without infra-red specification	<b>3,4,5,...11</b>	Welding	-
<b>6</b>	Sunglare filter with infra-red specification			

## OPTICAL CLASS

Optical Class	Spherical refractive power m <sup>-1</sup>	Astigmatic refractive power m <sup>-1</sup>	Difference in prismatic refractive power		
			horizontal base out	horizontal base in	vertical
<b>1</b>	± 0.06	0.06	0.75	0.25	0.25
<b>2</b>	± 0.12	0.12	1	0.25	0.25
<b>3</b>	+0.12 / -0.25	0.25	1	0.25	0.25

## PROTECTION AGAINST HIGH SPEED PARTICLES

Mechanical resistance	Impact level	Maximum speed	Diameter	Grams	Lens material	Eyewear	Goggles	Face shields
<b>A (T)</b>	High energy impact	190 m/s 684 km/h	ø 6 mm	0,86 gr	Polycarbonate			•
<b>B (T)</b>	Medium energy impact	120 m/s 432 km/h			Polycarbonate		•	•
<b>F (T)</b>	Low energy impact	45 m/s 162 km/h			Polycarbonate, acetate	•	•	•
<b>S</b>	Increased robustness	5,1 m/s 18,36 km/h	ø 22 mm	43 gr	CR39, Toughened glass	•	•	•

(T) if the impact letter (F, B or A) is followed by the letter T, then the frame protects against impact at extreme temperatures (-5°/ + 55°C)

## OPTIONAL REQUIREMENTS

<b>K</b>	Resistance to surface damage by fine particles
<b>N</b>	Resistance to fogging of oculars
<b>T</b>	Protection against high speed particles at extreme temperatures
<b>H</b>	Frame suitable for small head
<b>R</b>	Enhanced reflectance

## FIELD OF USE

SYMBOL	DESIGNATION	DESCRIPTION OF THE FIELD OF USE	EYEWEAR	GOGGLES	FACE SHIELD
<b>No symbol</b>	Basic use	Unspecified mechanical hazards and hazards arising from ultraviolet, visible, infra-red and solar radiation	•	•	•
<b>3</b>	Liquids	Liquids (droplets or splashes)		•	•
<b>4</b>	Large dust particles	Dust with a particle size > 5 µm		•	
<b>5</b>	Gas and fine dust particles	Gases, vapours, sprays, smoke and dust with a particle size < 5 µm		•	
<b>8</b>	Short circuit electric arc	Electrical arc due to a short circuit in electrical equipment			•
<b>9</b>	Molten metals and hot solids	Splashes of molten metal and penetration of hot solids		•	•

# Lens selection



## CLEAR POLYCARBONATE The clear vision lens

### FEATURES:

- Protects against impacts and UV radiations
- Can be used for prolonged periods as it does not create distortion or fatigue
- No colour distortion
- Available UV400 version for an increased UV protection
- Mirrored version (FM) gives protection from glare

### APPLICATIONS:

Mechanical work in good visibility conditions

STANDARDS: EN166/EN170  
MARKING: 2C-1.2  
VLT: 89%



## CLEAR CR39 The clear vision lens

### FEATURES:

- Good protection against scratches
- Excellent protection against chemical agents
- No colour distortion

### APPLICATIONS:

Chemical laboratories

STANDARDS: EN166/EN170  
MARKING: 2C-1.2  
VLT: 89%



## CLEAR GLASS The clear vision lens

### FEATURES:

- Good protection against scratches
- Excellent protection against chemical agents

### APPLICATIONS:

Chemical laboratories, painting, environments with abrasive suspended particulate

STANDARDS: EN166  
MARKING: -  
VLT: 89%



## CLEAR ACETATE The clear vision lens

### FEATURES:

- Superior performance of the anti-fog treatment also on the outer surface of the lens
- Very good resistance to chemicals and solvents
- Impact resistance marking F (45 m/s)

### APPLICATIONS:

Chemical laboratories, painting, environment with high humidity

STANDARDS: EN166  
MARKING: -  
VLT: 89%

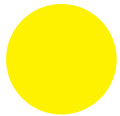

## YELLOW The enhanced contrast lens

### FEATURES:

- Protection against impacts, UV radiations and blue light (up to 480nm)
- Sharpens visual acuity in conditions of low visibility
- **Enhances the contrast**

### APPLICATIONS:

Surface inspection, mechanical work, ultra-violet light, work inside galleries, bad atmospheric conditions, shooting

MODELS: 5X6, 5X8, 505UP, 554, 557, 568, 553ZN

STANDARDS: EN166/EN170/EN172  
MARKING: 2C-1.2, 2C-1.2/5-1.4  
VLT: 86%  
SUNGLASS EQUIVALENCE: Shade 0



## ORANGE The UV525 blocking lens

### FEATURES:

- Protection against impacts, UV radiations
- **Protects against blue light up to 525nm**
- Enhances the contrast in low light condition

### APPLICATIONS:

Surface inspection, mechanical work, ultra-violet light, vulcanization, work with curing light lamp

MODELS: 5X3, 5X7, 546, 568, 568H

STANDARDS: EN166/EN170  
MARKING: 2-1.7  
VLT: 55%  
SUNGLASS EQUIVALENCE: Shade 1



## BlueE SM The relaxing lens

### FEATURES:

- Protection against impacts, UV radiations (absorbs > 99,9% of the rays up to 400nm)
- Protection against glare
- **Reduces eye fatigue in environments with predominance of yellow light**

### APPLICATIONS:

Mechanical work, works using incandescent/fluorescent lamps or sodium vapor lamps, outdoor work

MODELS: 505UP

STANDARDS: EN166/EN170  
MARKING: 2C-1.7  
VLT: 49%  
SUNGLASS EQUIVALENCE: Shade 1



## BROWN The linear protection lens

### FEATURES:

- Protection against impacts, UV radiations and visible light
- For sunlight and glare condition
- Good colour recognition - TSR (Traffic Signal Recognition)
- Linear spectral transmittance
- **Allows a better adaptation of the eye to changes in light condition**

### APPLICATIONS:

Outdoor work, mechanical work with risk of glare

MODELS: 5X3, 505UP, 557

STANDARDS: EN166/EN170/EN172  
MARKING: 2C-3/5-3.1  
VLT: 16%  
SUNGLASS EQUIVALENCE: Shade 3



**SMOKE**  
**The solar lens**

- FEATURES:
- Protection against impacts, UV radiations and visible light
  - **For sunlight and glare condition**
  - Good colour recognition – TSR (Traffic Signal Recognition)
  - **Flash Mirror version** with a mirrored coating for a better protection from glare

APPLICATIONS:  
Outdoor works, mechanical work with risk of glare

MODELS:  
5X7, 505UP, 513, 516, 568, 568H, 6X1  
versione FM: 5X3, 546, 554

STANDARDS: EN166/EN170/EN172  
MARKING: 2C-2.5/5-2.5, 2C-3/5-3.1  
VLT: 16%  
SUNGLASS EQUIVALENCE: Shade 3



**IR 1.7/3/4/5/6/7**  
**The welding lens set**

- FEATURES:
- Protection against impacts, UV and infrared (IR) radiations and glare produced by **welding processes**

APPLICATIONS:  
• IR 1.7 welder's aid  
• IR 3, 4 brazing, gas welding  
• IR 5, 6, 7 gas welding, flame cutting

MODELS:  
• IR 1.7: 5X7, 5X9, 539  
• IR 3: 5X3, 5X7, 5X9, 511, 539  
• IR 4: 5X9  
• IR 5 PC: 5X3, 5X7, 5X9, 511, 539, 541, 566, 601, 603, 604, 607  
• IR 5 VTR: 540, 566, 567, 603, 604, 618  
• IR 6: 5X9  
• IR 7: 5X9

STANDARDS: EN166/EN169  
MARKING: 1.7, 3, 4, 5, 6, 7  
VLT:  
IR 1.7: 45%, IR 3: 16%  
IR 4: 6%, IR 5: 2%,  
IR 6: 0.6%, IR 7: 0.2%



**BlueeE IR**  
**The IR protection lens set**

- FEATURES:
- Protection against infrared (IR) radiations
  - Absorbs yellow-orange radiations
  - **Reduces glare caused by molten glass or metal**

APPLICATIONS:  
• IR 4-2 glassworks – furnace work  
• IR 4-5 glassworks, metallurgy, foundries – casting control

MODELS:  
• IR 4-2: 5X9  
• IR 4-5: 5X9, 540

STANDARDS: EN166/EN171  
MARKING: 4-2, 4-5  
VLT:  
IR 4-2: 40%  
IR 4-5: 1%

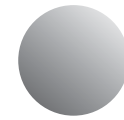

**POLAR LENS**  
**The anti-reflection lens**

- FEATURES:
- **Blocks luminous radiation depending on its polarization, stopping annoying reflections**
  - Good perception of contrasts and clear vision
  - Less eye strain
  - 100% UV protection

APPLICATIONS:  
Outdoor work, construction sites, road works, driving vehicles, oil platforms

MODELS: 549

STANDARDS: EN166/EN170/EN172  
MARKING: 2C-3/5-3.1  
VLT: 16%  
SUNGLASS EQUIVALENCE: Shade 3



**AMBER**  
**Intense Light Protection**

- FEATURES:
- 100% protection against UV radiations
  - 100% protection against bluee light (up to 530nm)
  - Perfect protection in bright sunlight
  - **Excellent protection against glare produced by intense light sources**

APPLICATIONS:  
LED sources manufacturers (quality control), IPL (staff and patients), ophthalmology post-surgery, use of lamps emitting bluee light: Wood's lamp, germicidal lamp

MODELS: 5X3, 5X7

STANDARDS: EN170  
MARKING: 2-5  
VLT: 1.7%  
SUNGLASS EQUIVALENCE: -



**IN/OUT**  
**The anti-glare clear lens**

- FEATURES:
- Multilayer reflective coating deposited on the outer surface of the lens
  - **Protects against glare and provides high visibility in extreme conditions**

APPLICATIONS:  
Fork lift truck, mechanical work, work with transition between dark and bright environments

MODELS: 5X6, 5X7, 5X8, 553ZN

STANDARDS: EN166/EN170/EN172  
MARKING: 2C-1.7/5-1.7  
VLT: 55%  
SUNGLASS EQUIVALENCE: Shade 1



**G15**  
**The natural vision solar lens**

- FEATURES:
- **Solar Lens designed on the basis of the spectral luminous efficiency curve of the human eye**
  - Very relaxing
  - Perfect colour recognition (TSR)

APPLICATIONS:  
Outdoor work, construction sites, road works, driving vehicles

MODELS: 5X4, 5X6, 5X8, 506UP, 508, 553ZN

STANDARDS: EN166/EN170  
MARKING: 2C-3/5-3.1  
VLT: 15%  
SUNGLASS EQUIVALENCE: Shade 3



**UVR**  
**The global filter UV-IR-SUN**

- FEATURES:
- 100% UV protection
  - Optimal protection against IR radiations
  - High VLT for good visibility in dark environments
  - Good colour recognition (TSR)
  - Solar protection

APPLICATIONS:  
Glasswork, quality control, foundry, Artificial Optical Radiations (AOR)

MODELS: 5X7, 5X9, 539

STANDARDS: EN166/EN169/EN170/EN171/EN172  
**MARKING: 1.7/2C-1.7/4-1.7/6-1.7**  
VLT: 46%  
SUNGLASS EQUIVALENCE: Shade 1



# X GENERATION

Innovative solutions designed to revolutionise safety eyewear market: from the union of ergonomics, style and quality comes the exclusive Univet X-Generation line.

Aggressive design and attention to detail has been applied for the first time to protection equipment, providing the operator optimal comfort with no points of pressure on the face, X-generation is the new frontier in safety eyewear.

The result of careful analysis, not only in quality of materials and design but also in ergonomics, guarantee these spectacles the highest adaptability to every user thanks to their exclusive frame.







# 5X3

31g

## HIGH-TECHNOLOGY

Normally the geometry of the spectacle is bound by the rigidity of the lens. The structure of the model 5X3 is realised with the exclusive FLD (Floating Lens Design) technology that allows to anchor the lens only to a single point of the frame, while ensuring extreme stability and total possibility of self-adaptation to the face.



5X3.01.35.00  
Frame: black/green  
Lens: clear



5X3.03.33.00  
Frame: black/orange  
Lens: clear



5X3.12.35.02  
Frame: black/green  
Lens: smoke FM



5X3.03.33.04  
Frame: black/orange  
Lens: orange



5X3.03.33.08  
Frame: black/orange  
Lens: brown



5X3.03.33.09  
Frame: black/orange  
Lens: amber



5X3.03.35.30  
Frame: black/green  
Lens: green IR3



5X3.03.35.50  
Frame: black/green  
Lens: green IR5



- Exclusive UDC coating
- Lens with FLD (Floating Lens Design) technology
- Frame engineered to cushion the contact points on the face
- Extended 9 base wraparound lens, provides extra coverage around the eyes
- Ventilation system
- The spectacle fits the face without adjustments



The studied design and the careful choice of materials guarantee 5X3 a perfect fit to every face without the need of additional mechanical adjustments. The eyewear self-adapt to the face of each operator so that the user can find the perfect balance between comfort and safety.

27g

# 5X4

## ITALIAN STYLE

Univet experience matured in the design of fashion eyewear is shown in the safety field through 5X4 model. The sleek design, developed in the internal design office, and the refined finishing make this model a perfect example of the Italian style.



- Extreme care of details and excellent ergonomics for a trendy and comfortable model
- Anallergic nose pad for comfort without slippage
- Wraparound lens design provides extra side coverage
- The exclusive painted frame confers elegance and style



5X4.03.30.05  
Frame: black painted  
Lens: G15  
UV400



5X4.03.40.00  
Frame: red painted  
Lens: clear  
UV400



5X4.13.10.00  
Frame: blue painted  
Lens: clear FM  
UV400

# 5X6

softpad technology

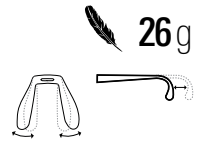

## SPORTY DESIGN

The need to wear protective eyewear for long periods requires that they meet comfort features such as lightness, stability and fit. The unique FLD (Floating Lens Design) technology combined with the presence of SoftPad terminal and the nose pad adjustment allow the operator to get used to work in harmony with the device.



5X6.01.00.00  
Frame: black/orange  
Lens: clear  
UV400



5X6.03.11.00  
Frame: gun metal/green  
Lens: clear  
UV400



5X6.03.00.05  
Frame: gun metal/green  
Lens: G15  
UV400



5X6.31.11.00  
Frame: gun metal/green  
In/Out  
UV400



5X6.03.00.03  
Frame: black/orange  
Lens: yellow  
UV400



- Sporty and wrap-around design
- Lens with FLD (Floating Lens Design) technology
- SoftPad technology
- Light and comfortable device, ideal for prolonged use
- Adjustment of temples in length
- Adjustable soft and anatomical nose pad



SoftPad technology is a patented system designed to provide perfect stability to the safety glasses and full adaptability to the face of the user. The pressure exerted by the temples on the head is distributed on the whole supporting area of the arm for a comfortable and stable fit.

# 5X7

## THE ULTIMATE OVERSPEC

Normal prescription glasses alone do not guarantee adequate protection in risky environments, at the same time those suffering from visual defects cannot work without the aid of corrective lenses. The model 5X7, ultimate OTG, offers maximum protection and the comfort of operating with their own spectacles.



- The ultimate OTG to prescription spectacles
- The careful design of the frame prevents the overlapping of the temples for an absolute comfort
- SoftPad technology
- Adjustment of temples in length
- Wide range of filters



The R & D department is constantly looking for innovative solutions to be used in Univet products. The development of new lenses for protection from optical radiation in special applications is one of the key points of this activity. The In / Out, Amber and UVR lenses, exclusive of Univet, increase the versatility of the model 5X7 offering a truly universal product usable in a wide variety of application fields.

	5X7.01.00.00 Frame: black/orange Lens: clear UV400
	5X7.03.11.00 Frame: gun metal/green Lens: clear UV400
	5X7.31.11.00 Frame: gun metal/green Lens: In/Out UV400
	5X7.01.11.02 Frame: gun metal/green Lens: smoke UV400
	5X7.01.00.09 Frame: black/orange Lens: amber UV400
	5X7.03.00.04 Frame: black/orange Lens: orange UV525
	5X7.01.11.47 Frame: gun metal/green Lens: UVR
	5X7.01.11.17 Frame: gun metal/green Lens: green IR1.7
	5X7.01.11.30 Frame: gun metal/green Lens: green IR3
	5X7.01.11.50 Frame: gun metal/green Lens: green IR5



# 5X8

softpad  
technology



## EFFECTIVE PROTECTION

The 5X8 represents the essence of protective eyewear. The innovative SoftPad technology combines to the excellent coverage of the eye area and the angle adjustment of the temples for exceptional comfort and stability. The range of lenses and treatment is complete and highly performing to meet the protection needs of several working environments.



5X8.01.00.00  
Frame: black/orange  
Lens: clear  
UV400



5X8.03.11.00  
Frame: gun metal/green  
Lens: clear  
UV400



5X8.03.00.05  
Frame: gun metal/green  
Lens: G15  
UV400



5X8.31.11.00  
Frame: gun metal/green  
Lens: In/Out  
UV400



5X8.03.00.03  
Frame: black/orange  
Lens: yellow  
UV400



- Over-moulded nose pad for comfort without pressure
- Adjustment of temples in length and inclination
- Winning and ergonomic line to adapt to all users
- SoftPad technology



The enveloping line and the technical solutions adopted enable the model 5X8 to conform perfectly to any face. The carefully calibrated geometry and the selected materials give the device solidity and robustness for a feeling of absolute safety.



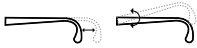

# 5X9

## ELEGANT AND MODULAR

The two-lens structure of the model 5X9 permits to provide the device with alternative materials to polycarbonate lenses, offering protection to a greater number of professional fields. The integrated flip-up perfectly combines with the glasses forming a unique modular system for maximum flexibility of use, made possible by the wide range of filters in the catalog.



- Univet project, innovative design
- Integrated side shields with ventilation system
- Adjustable temples with SoftPad technology
- Clear lenses available in different materials
- Additional flip with protective filters for special applications



The line of protective prescription eyewear is the excellence in Univet manufacturing. Each device is custom made starting from the needs of the user, allowing even workers suffering from visual defects to work in total safety. 5X9 model, available in two sizes, combines style and customized protection.

	<b>5X9.01.11.00</b> Frame: gun metal/orange Lens: clear PC ⊗+
	<b>5X9.03.00.00</b> Frame: gun metal/green Lens: clear PC ⊗+ ⊕+
	<b>5X9.10.00.00</b> Frame: gun metal/green Lens: clear CR39
	<b>5X9.20.00.00</b> Frame: gun metal/green Lens: clear glass
	<b>5X9R.00.17</b> Flip: green IR1.7 ⊗
	<b>5X9R.00.30</b> Flip: green IR3 ⊗
	<b>5X9R.00.40</b> Flip: green IR4 ⊗
	<b>5X9R.00.47</b> Flip: UVR ⊕+ ⊗
	<b>5X9R.00.50</b> Flip: green IR5 ⊗
	<b>5X9R.00.60</b> Flip: green IR6 ⊗
	<b>5X9R.00.70</b> Flip: green IR7 ⊗
	<b>5X9R.20.42</b> Flip: blue IR4-2 glass
	<b>5X9R.20.Y2</b> Flip: blue didymium glass
	<b>5X9R.20.Y3</b> Flip: blue 4-5 glass

# 6X1

softpad  
technology



## PERFECT HYBRID

6X1 combines the lightness of a spectacle to the benefits of a mask. The adjustable temples with SoftPad technology can be easily replaced with the elastic band included for absolute versatility; comfort and ease of use are thus added to protection against drops, sprays and large dust particles guaranteed by the special design of the internal rubber.



6X1.00.00.00  
Frame: gun metal/green  
Lens: clear



6X1.00.00.01  
Frame: gun metal/green  
Lens: smoke



6X10.00.99  
RX insert



- Wide lens for a field of view without distortion
- Temples adjustable in length and inclination with SoftPad technology
- Sophisticated indirect ventilation system
- Soft internal rubber for comfort without local pressure
- Certified according to EN166 point 3 (droplets and splashes) and point 4 (large dust particles)
- RX insert available



6X1 is unique for completeness and modularity: each product provides certified protection in accordance to point 3 and 4 of EN166 either mounting the temples or the elastic band. The RX insert for custom made prescription lenses and the availability of the smoke lens further extend the wide possibility of using the model to additional fields of application.

75g



# 6X3

NEW

## NEXT GENERATION GOGGLE

Univet Research and Development department designed 6X3 goggle with the intention of combining a higher level of protection and an innovative style. The result is an amazing product for performance and design, with a panoramic lens offering excellent peripheral vision that can be used comfortably with any corrective eyewear, assuring a perfect fit.



6X3.00.00.00  
Frame: gun metal/green  
Lens: clear  
**UDC**



6X3F.01.00  
Frame: light smoke



- Panoramic lens can be perfectly worn over prescription glasses
- Exclusive UDC coating
- **Facial support compatible with half masks**
- Additional facial protection
- Indirect ventilation system assures certified protection against drops and splashes
- Category III° PPE
- Impact resistance at 432 km/h, even at extreme temperatures



nEXxt range was created to guarantee the best possible protection to the worker also in case of interaction of the eyewear with other PPE. The originality of the 6X3 model is expressed in the design of the facial support that ensures a proper seating of respiratory masks and half masks and the use of additional facial protection that provides total protection to the operator's face.

# SPECTACLES

The face of each one has different facial characteristics, but everybody has the right to the best protection when exposed to various risks in the workplace. Univet glasses are designed on the basis of indepth ergonomic studies, ensuring comfort and an excellent fit. The settings of the nose pad and the terminals' adjustments in length and inclination can further adapt the device shaping it to the face of each user for an optimal comfort.







# 501

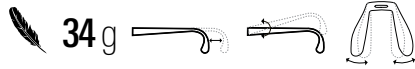

- Spectacle with wide coverage area and perfect adherence to the face
- Micrometric adjustment of temples length
- Step-free adjustment of the front angle
- Vented side shields
- Adjustable nose pad



**501.00.00.00**  
Frame: silver  
Lens: clear PC



**501.00.00.11**  
Frame: silver  
Lens: clear PC



**501.00.00.31**  
Frame: silver  
Lens: CR39 clear

# 503

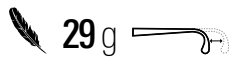

- Adjustment of temples in length
- Built-in side shields
- Eyebrow protection
- The uncoated (UC) version can be sterilized



**503.00.00.00**  
Frame: clear  
Lens: clear UC



**503.00.70.11**  
Frame: light blue  
Lens: clear

**NEW**

# 505<sup>UP</sup>



- Extremely light and encircling
- Elastic structure, extremely flexible and resistant
- New temple for a better ergonomoy
- Optimal comfort and fit thanks to the soft adjustable nosepad
- Neck cord included in the packaging



**505U.00.00.00**  
Frame: clear  
Lens: clear



**505U.00.00.02**  
Frame: smoke  
Lens: smoke



**505U.00.00.11**  
Frame: clear  
Lens: clear



**505U.00.00.18**  
Frame: brown  
Lens: brown



**505U.00.00.19**  
Frame: yellow  
Lens: yellow



**505U.00.00.37**  
Frame: blue  
Lens: blue Smart Mirror

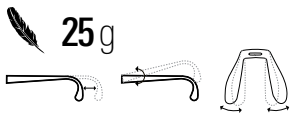

# 506UP

NEW

## FULL COLOUR TECHNOLOGY

506UP presents technical and aesthetic improvements. The panoramic and wrapping lens is available with AF+ and AS+ coatings for superior performance in all conditions. The temples with rubber tips and adjustable in length and inclination, the total adaptability of the nosepad and the new range of vibrant colors allow a high degree of customisation of the device.

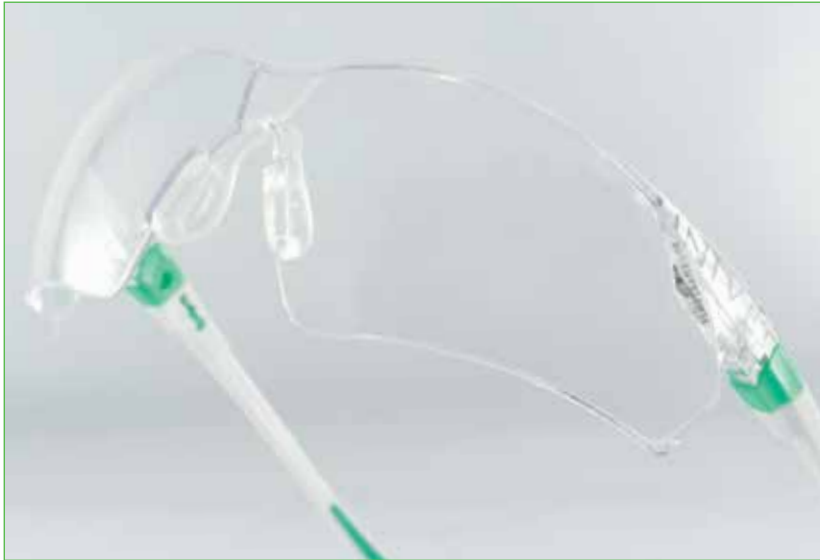

- New technical features and design
- Panoramic wrapping lens available with AF+ and AS+ coatings
- Temples regulation in length and inclination
- Soft terminal tips to eliminate local pressure
- Optimal comfort and fit thanks to the soft adjustable nosepad
- New range of colours



Flexible, reactive and attentive to the needs of the market, Univet has always offered products tailored to the needs of individual users, not only in terms of work applications, but also of comfort and design. For this reason, it has been developed a solution designed specifically for women: dedicated colors in a lightweight and wraparound frame that fits well the feminine features.



**506U.03.00.00**  
 Frame: white/green  
 Lens: clear  
 UV400



**506U.03.02.00**  
 Frame: white/pink  
 Lens: clear  
 UV400



**506U.04.03.00**  
 Frame: black/orange  
 Lens: clear  
 UV400



**506U.04.04.05**  
 Frame: black/green  
 Lens: G15  
 UV400



**506U.06.01.00**  
 Frame: black/green  
 Lens: clear  
 UV400

SPECTACLES

# 507

 29g



- Soft terminal tips by over moulded system
- Built-in side shields
- Temples regulation in length
- Micrometric friction adjustment of the front angle

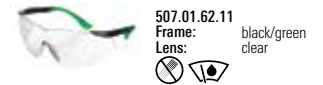

# 508

 29g



- Modern design
- Extremely lightweight for comfort even during prolonged use
- Temples made with over-moulding technology for an excellent fit
- Wraparound lens with integrated side shields
- Eyebrow protection

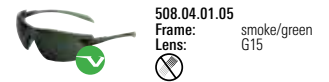

# 511

 34g  



- Adjustment of temples in length and inclination
- Built-in side shields
- Frame made of anallergic material
- Available the version certified to small faces (511.03.01.00H)



## Children & Small Faces

Recreational and didactic laboratories and school visits require total safety specifically fitted for children: the models 511H and 568H, realized and certified appropriately for small faces, give children ideal protection thanks to wrap-around polycarbonate lenses and extreme lightness.

# 513

24g

backtobasic



- Colourful temples in anallergic rubber
- Highly suitable for customization
- Non-slip rubber nose pad
- Eyebrow protection



513.01.00.00  
Frame: clear/orange  
Lens: clear



513.01.10.02  
Frame: smoke/orange  
Lens: smoke



513.02.00.00  
Frame: clear/orange  
Lens: clear

# 516

24g

backtobasic



- Innovative line
- New temple design for a better ergonomoy
- Wraparound model, guarantees optimal lateral protection
- Anatomical soft rubber nose bridge
- Colourful temples in anallergic rubber



516.01.00.00  
Frame: clear/green  
Lens: clear



516.01.01.02  
Frame: smoke/green  
Lens: clear



516.11.00.00  
Frame: clear/green  
Lens: clear FM

# 519

43g

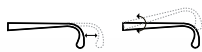

- Overmoulded terminal for better comfort and stability
- Side venting
- Adjustment of temples in length and inclination
- Can be worn over prescription glasses



519.00.00.00  
Frame: black/grey  
Lens: clear



519.00.00.11  
Frame: black/grey  
Lens: clear

Essentially

Univet

backtobasic

Light and comfortable, the spectacles of Back to Basic line represent the essence of protection. Handiness and versatility together with bright colours and fully wearability casting a glance at style. Obviously Univet.

SPECTACLES

# 520

 43g



- Side venting
- Can be worn over prescription glasses
- The uncoated (UC) version can be sterilized



520.11.00.00  
 Frame: clear  
 Lens: clear UC

# 528

 27g  



- Temples regulation in length
- Built-in sideshields
- Adjustment of the front angle
- Wide lens for an extended protection



528.00.01.00  
 Frame: blue  
 Lens: clear





528.00.01.11  
 Frame: blue  
 Lens: clear

**NEW**

# 529

 23g  



- Spherical lens for a wide field of view
- Adjustment of temples in length and inclination
- Temple's terminal tips realised with over-moulding technology gives the glasses an excellent wearability
- New colours



529.00.05.00  
 Frame: black/orange  
 Lens: clear



529.00.06.11  
 Frame: gun metal/green  
 Lens: clear



# 532

27g

**NEXXT** 

- Metal frame with curled terminal
- **Designed for use with NBC masks**
- Corrective version available



## ATEX

Model 532 is tested to be used in ATEX regulated environments. The reduced size of the frontal and the thin section the arms allow the perfect housing of the device within NBC masks.



532.03.00.00  
Frame: palladium clear  
Lens:   



532.04.00.00  
Frame: palladium clear  
Lens:  

SPECTACLES

NEW

# 535



36g 

- Wide lens for optimal face protection without front frame
- Optimal protection and panoramic view
- Adjustment of temples in length and inclination
- Eyebrow protection
- RX insert available
- New colours



535.00.05.00  
Frame: black/orange clear  
Lens: 



535.00.06.11  
Frame: gun metal/green clear  
Lens:   

# 539

45g (glass version) / 28g (polycarbonate version) 

- Built-in vented side shields
- Soft terminal tips eliminate local pressure and increase wearability
- Adjustment of temples in length and inclination
- Wide range of filters



539.00.01.00  
Frame: blue/grey clear PC  
Lens: 



539.00.01.11  
Frame: blue/grey clear PC  
Lens:   



539.10.01.00  
Frame: blue/grey clear glass  
Lens: 



539.20.01.31  
Frame: blue/grey clear CR39  
Lens: 



539.00.02.47  
Frame: black UVR  
Lens: 

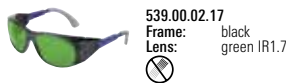

539.00.02.17  
Frame: black green IR1.7  
Lens: 



539.00.02.30  
Frame: black green IR3  
Lens: 

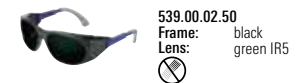

539.00.02.50  
Frame: black green IR5  
Lens: 

# 543

28g 



- Ultra-light goggle made of nylon
- Available both with temples and elastic cord or with adjustable elastic band
- Soft foam for improved adherence to the face



### Field of use

543 model is certified in accordance with EN166 point 3 (droplets and splashes) and paragraph 4 (large dust particles) thus providing to the user an actually increased eye protection.

543.00.01.11  
Frame: blue with elastic band  
Lens: clear



543.01.01.11  
Frame: blue with temples  
Lens: clear



NEW

# 546

25g 



- Extremely lightweight and modern spectacle with a sporty line
- Wraparound polycarbonate lens with integrated side shields
- Temples equipped with overmoulding technology guarantee excellent fit and comfort
- Non-slip rubber nose pad
- New colours



546.01.42.00  
Frame: black/orange  
Lens: clear



546.12.45.02  
Frame: black/green  
Lens: smoke FM



546.03.45.00  
Frame: black/green  
Lens: clear



546.03.42.04  
Frame: black/orange  
Lens: orange



UV525

# 549

25g 



- Ergonomic temples, no adjustment is necessary
- Exclusive G15 solar lens available also in polarized version
- Anatomically shaped nose pad adapts to all face

### Polar Lens

High technology lens developed to eliminate reverberation and reduce glare. Its peculiar structure blocks luminous radiation depending on its polarization, letting pass only direct font rays, significantly improving the ability of vision in bright light.

549.03.00.05  
Frame: black  
Lens: G15



549.M1.11.12  
Frame: black  
Lens: G15 Polar



NEW

19g



# 553ZERONoise

## SOUND PROTECTION

The innovative 553 ZERONoise is equipped with patented temples specially designed to facilitate the combined use with hearing protection devices: the shorter terminals and the reduced sections cancel the interference with cushions avoiding the ear muff loses part of its attenuation capacity. The flexible and shaped temples give the operator comfort, and allow to wear the glasses without having to remove the ear muffs.



- Wraparound model, guarantees optimal lateral protection
- Light and handy, made entirely in polycarbonate, weight only 19 gr
- **Temples with reduced section designed for a perfect interaction with ear muffs**
- New lens available (G15 and In/Out)



553Z.01.00.00  
Frame: clear  
Lens: clear



553Z.01.01.03  
Frame: yellow  
Lens: yellow



553Z.01.02.05  
Frame: G15  
Lens: G15



553Z.34.00.00  
Frame: In/Out  
Lens: In/Out



ZERONoise

SPECTACLES

TEST	NOISE LEVEL [dB]	ATTENUATION [dB]	LOSS OF ATTENUATION [dB]	LOSS OF ATTENUATION [%]
NO EAR MUFF	95.0			
WITH EAR MUFF	71.0	24.0		
<b>553 ZERONoise</b>	<b>74.8</b>	<b>20.2</b>	<b>-3.8</b>	<b>-15.8%</b>
OVERSPEC	83.9	11.1	-12.9	-53.8%
SAFETY EYEWEAR	81.3	13.7	-10.3	-42.9%

# 551

**NEW**

45g  





- Flexible brow guard against reflected light, dust and spray from above
- Adjustment of temples in length and inclination
- Wide lens for optimal face protection and panoramic view
- RX insert available
- New colours



551.03.31.00  
 Frame: gun metal/green  
 Lens: clear

# 554

30g  



- Model with sporty and colourful line
- Overmoulded nose bridge and temples for maximum comfort
- Rubber eyebrow protection to better absorb impacts
- Adjustment of temples in length



554.03.03.00  
 Frame: black/green  
 Lens: clear



554.03.01.03  
 Frame: black/grey  
 Lens: yellow



554.12.03.02  
 Frame: black/green  
 Lens: smoke FM

# 557

38g 



- Metal frame with essential and wrapping design
- Temple tips with metal core for easy adjustment
- Neoprene front support
- Flex hinges



557.03.00.00  
 Frame: metal grey  
 Lens: clear



557.03.00.03  
 Frame: metal grey  
 Lens: yellow  
 UV400



557.03.10.08  
 Frame: metal black  
 Lens: brown  
 UV400

# 566

 **54 g** (glass version) / **36 g** (polycarbonate version)



- Two-lens eyewear equipped with tilting vented side shields
- Interchangeable lenses available
- Central screw for quick lens replacement

### Glass



**566.01.00.00**  
Frame: black  
Lens: clear



**566.01.00.50**  
Frame: black  
Lens: green IR5



**137.00.32**  
Lens: clear



**137.00.33**  
Lens: green IR5

### Polycarbonate



**566.00.00.00**  
Frame: black  
Lens: clear



**566.00.00.50**  
Frame: black  
Lens: green IR5



**137.00.34**  
Lens: clear



**137.00.35**  
Lens: green IR5

SPECTACLES

# 567

 **46 g**



- Two-lens eyewear equipped with tilting vented side shields
- Central screw for quick lens replacement
- Glass lenses available in clear version or green shade 5 for welding



**567.00.00.00**  
Frame: black  
Lens: clear glass



**567.00.00.50**  
Frame: black  
Lens: green IR5 glass

# 568

 **23 g**



- Economic spectacle ideal for essential protection
- Lightweight and handy, entirely made of polycarbonate, weighs only 23 grams
- Available the version certified to small faces (568.01.00.00H)
- Highly suitable for customization



**568.01.00.00**  
Frame: clear  
Lens: clear



**568.02.01.00**  
Frame: smoke  
Lens: clear



**568.01.00.00H**  
Frame: clear  
Lens: clear



**568.01.01.02**  
Frame: smoke  
Lens: smoke



**568.02.01.02**  
Frame: smoke  
Lens: smoke



**568.01.03.03**  
Frame: yellow  
Lens: yellow



**568.02.09.04**  
Frame: smoke  
Lens: orange  
 **UV525**



**568.02.09.04H**  
Frame: smoke  
Lens: orange  
 **UV525**



# PRESCRIPTION

Combining the maximum practicality of use, comfortable and lightweight models in conjunction with corrective lenses, allows even those with visual defects (myopia, hyperopia, astigmatism or presbyopia) to work safely.

These products are recognised as II Category PPE and certified according to EN166 standard. All Univet prescription glasses are tailor-made. Starting from the needs and preferences of each user the production department creates a specific product with all the assurance of "Made in Italy".

On all Univet frames can be mounted monofocal, bifocal and progressive lenses made of polycarbonate or CR39.

	POLYCARONATE	CR39
MECHANICAL RESISTANCE	EXCELLENT FT	GOOD S
UV RPROTECTION	EXCELLENT 2C-1.2	EXCELLENT 2C-1.2
SCRATCH RESISTANCE	EXCELLENT K	GOOD
CHEMICAL RESISTANCE	DECENT	EXCELLENT
OPTICAL CLASS	1	1



# Technical specification

## Monofocal polycarbonate lens

### Construction limits:

Positive lenses: sphere and cylinder sum +8.50  
 Negative lenses: sphere and cylinder sum -10.00

Standard lenses: sphere +2/-6 cylinder 2  
 Non-standard lenses: diopters out of the limits reported above for standard lenses

Refractive index	<b>1.590</b>
Abbe number	<b>31</b>
Specific weight g/cm <sup>2</sup>	<b>1.20</b>
UV protection	<b>390 nm</b>
Category	<b>0</b>

## Bifocal polycarbonate lens

### Construction limits:

Positive lenses: sphere and cylinder sum +6,25  
 Negative lenses: sphere and cylinder sum -6,25  
 Standard minimum addition 1  
 Standard maximum addition 3.50

bifo carbolite st 28	clear
Refractive index	<b>1.590</b>
Abbe number	<b>31</b>
Specific weight g/cm <sup>2</sup>	<b>1.20</b>
UV protection	<b>400 nm</b>
Category	<b>0</b>
Product code	<b>BP</b>

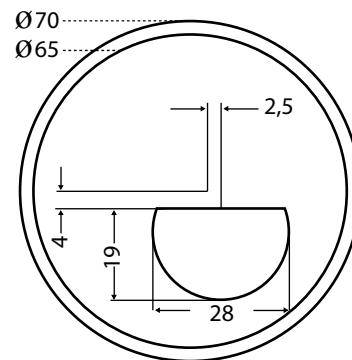

## Standard progressive lens

### Construction limits:

Positive lenses: sphere and cylinder sum +7,00  
 Negative lenses: sphere and cylinder sum -7,00  
 Standard minimum addition 1  
 Standard maximum addition 3,00  
 Non-standard addition:  
 0,50/0,75/3,25/3,50/3,75/4,00

<ul style="list-style-type: none"> <li>. lens channel 14mm</li> <li>. minimum fitting height 18mm</li> <li>. specific optimization for each addition</li> <li>. wider near-field vision area</li> <li>. easy and quick adaptation</li> <li>. clear view through all the lens areas</li> <li>. relaxed and balanced binocular vision</li> <li>. natural compensation of convergence</li> </ul>
---

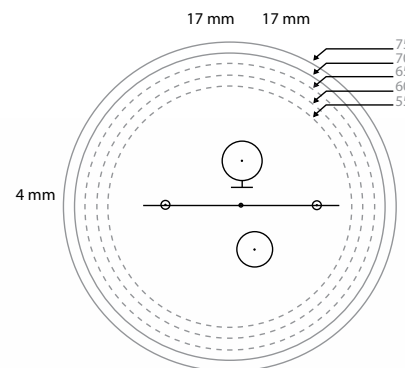

# 5X9



- Integrated side shields with ventilation system
- Adjustable temples with SoftPad technology
- Additional flip with protective filters for special applications
- Available in two calibers



58 □ 16 x 110-120

54 □ 16 x 110-120

⊕ (PC version)

# 530



- Ultra-light polycarbonate frame
- Built-in vented side shields
- Temples with metal core

51 □ 25 x 115-132

⊕ (PC version)

# 532



- Metal frame with curled terminal
- **Designed for use with NBC masks**
- Tested to be used in ATEX regulated environments
- Jointed side shields

51 □ 15 x 135

⊕ (PC version)

# 539



- Frame with wide coverage area
- Built-in vented side shields
- Soft terminal tips eliminate local pressure and increase wearability
- Two calibres available (56 – 59)



56 □ 16 x 132-142  
59 □ 15 x 132-142

⊗<sup>+</sup> (PC version)

# 541



- New temples with metal core for easy adjustment
- Integrated side shields and brow protection
- Available in two calibers



54 □ 16 x 126  
58 □ 16 x 126

⊗<sup>+</sup> (PC version)

# 552

29g



- Anallergic nylon frame
- Temples with metal core for easy adjustment
- Adjustable nose pad made of non-slip rubber
- Available different near-vision corrections



## Prescription

The models combine safety eyewear with the corrections for near-vision. This solution allows everybody to get immediately a prescription glasses with the certainty of a PPE certified according to the standards regulating protective eyewear.

552.00.00.97-150  
Frame: matt blue  
Lens: +1,50  
⊗

552.00.10.97-200  
Frame: grey  
Lens: +2,00  
⊗

552.00.20.97-250  
Frame: painted blue  
Lens: +2,50  
⊗

## Metal frame

Updated lines and selected materials make up a complete range of custom-made devices. A clean and attractive design, four models made of nickel-free metal to meet different safety requirements without losing in style.

# 536.05



- Frame made of anodized nickel-free metal
- Anallergic and non-slip terminals
- Anallergic PVC nose pads
- Riveted side shields

**54 □ 19 x 140**

⊗<sup>+</sup> (PC version)

# 536.06



- Frame made of anodized nickel-free metal
- Anallergic and non-slip terminals
- Anallergic PVC nose pads
- Riveted side shields
- Available in two calibers

**51 □ 19 x 135**

**54 □ 19 x 135**

⊗<sup>+</sup> (PC version)



# 536.07



- Frame made of anodized nickel-free metal
- Anallergic and non-slip terminals
- Anallergic PVC nose pads
- Riveted side shields

**50 □ 18 x 140**

⊗<sup>+</sup> (PC version)

# 536.08



- Frame made of anodized nickel-free metal
- Anallergic and non-slip terminals
- Anallergic PVC nose pads
- Riveted side shields

**53 □ 19 x 140**

⊗<sup>+</sup> (PC version)



## RX insert

The RX insert is a special product that allows to combine normal eyewear with corrective lenses. This product permits the merger, the RX Insert and PPE product into a single product, increased protection combined with the correction of visual defects.

The insert is strictly personal as it is built upon specific request in accordance with medical prescription and can be easily applied and removed from the protective product.

# 535

Cod. 1110052  
RX insert



# 551

Cod. 1110052  
RX insert



# 6X1

Cod. 6X10.00.99  
RX insert



# 611

Cod. 601.OP.00.99  
RX insert



# 601

Cod. 601.OP.00.99  
RX insert



# GOGGLES

The goggle provides the wearer a greater sense of security and allows the protection of the eye area to be increased thanks to a perfect fit to the face, a wide coverage area and a superior impact resistance. The certification requirements 3 (droplets and splashes of liquid), 4 (large particles of dust), 5 (gas and fine dust) and 9 (molten metals and hot solids) complete the protective characteristics of this product.







# 6X1



- Wide lens for a field of view without distortion
- Temples adjustable in length and inclination with SoftPad technology
- Sophisticated indirect ventilation system
- Soft internal rubber for comfort without local pressure
- Certified according to EN166 point 3 (droplets and splashes) and point 4 (large dust particles)
- RX insert available



# 6X3



- Panoramic lens can be perfectly worn over prescription glasses
- Exclusive UDC coating
- **Facial support compatible with half masks**
- Additional facial protection
- Indirect ventilation system assures certified protection against drops and splashes
- Category III° PPE
- Impact resistance at 432 km/h, even at extreme temperatures



## X-Generation

Innovative solutions able to revolutionize safety eyewear market: from the union of ergonomics, style and quality comes the exclusive Univet X-Generation line. Aggressive design and attention to details applied for the first time to protection equipment, productive and technical peculiarity for an optimal comfort with no points of pressure on the face, X-generation is the new frontier in safety eyewear. Result of careful analysis, not only in quality of materials and design but also in ergonomics, these spectacles guarantee the highest adaptability to every user thanks to their exclusive frame.



118g

# 601

## HIGH PERFORMANCE AND VERSATILITY

The extent of the 601 goggle range provides superior versatility: the various technologies of ventilation systems, the lenses available, in polycarbonate, acetate and welding version, and the insert for additional corrective lenses make it suitable for a wide range of sectors always with a high-level of performance.



- Wide field of vision for a high-tech goggle
- Different ventilation systems (unvented, indirect ventilation)
- Also acetate and welding version available
- The anatomic nose pad fits perfectly to all faces
- The adjustable headband and the soft frame effectively distribute the pressure on the face
- RX insert available
- Category III° PPE (PC version)



### ACETATE LENS

To better satisfy the different safety needs Univet offers the model 601 with acetate lens. This special material has an anti-fog treatment with superior performance and offers excellent resistance against attack by chemicals or solvents and full UV protection.



**601.00.77.00**  
 Frame: indirect vented with foam  
 Field of use: 3 4 9  
 Lens: clear PC



**601.02.77.00**  
 Frame: blue - indirect vented  
 Field of use: 3 4 9  
 Lens: clear PC



**601.02.77.01**  
 Frame: blue - indirect vented  
 Field of use: 3 4  
 Lens: clear acetate



**601.03.07.00**  
 Frame: clear - unvented  
 Field of use: 3 4 5 9  
 Lens: clear PC



**601.03.07.01**  
 Frame: clear - unvented  
 Field of use: 3 4 5  
 Lens: clear acetate



**601.02.06.50**  
 Frame: smoke  
 indirect vented  
 Field of use: 3 4 9  
 Lens: green IRS



**042.065**  
 Spare PC lens clear

**042.066**  
 Spare acetate lens clear

GOGGLES



# 602

77g



- Essential frame ideal for each type of fit
- Adjustable elastic fabric headband
- Polycarbonate lens
- Indirect ventilation system
- OTG



602.01.00.00  
 Frame: clear  
 Field of use: 3 4  
 Lens: clear



602.01.00.01  
 Frame: clear  
 Field of use: 3 4  
 Lens: clear UC

# 611

128g

## NEXXT



- Frame, lens and elastic strap of fireproof material
- Wide elastic band with silicone inserts improves stability
- The double lens with thermal breakage technology protects against heat, fogging and impacts
- **Variant available with quick-release claws suitable for use with different types of helmet**
- RX insert available
- Category III° PPE



611.00.10.01  
 Frame: red  
 Field of use: 3 4 5 9  
 Lens: clear



04.20.65/A1.6  
 Spare lens



611.K0.10.01  
 Frame: red  
 Field of use: 3 4 5 9  
 Lens: clear

## Firefighters goggle

Univet meets the demands of professionals that need maximum protection working in extreme conditions through the production of high-tech products. Fire Brigade and Civil Defence personnel can find in 611FF goggle the ideal device: designed according to the specific needs of the sector and made of selected materials this device can provide high performance and total protection.



# 619

 86 g



- Linear and compact design
- Can be worn over any prescription spectacles thanks to its spherical lens
- Version unvented or provided with indirect ventilation system
- Wide, fully adjustable headband
- Category III° PPE



**619.02.01.00**  
 Frame: blue  
 indirect vented  
 Field of use: 3 4 9  
 Lens: clear  



**619.03.01.00**  
 Frame: blue - unvented  
 Field of use: 3 4 5 9  
 Lens: clear  

# 620

 91 g



- Innovative technology, perfect mix of ergonomics and design
- Spherical panoramic lens for the highest performances
- Soft TPR frame assures optimal level of comfort
- Exclusive UDC coating
- Sophisticated indirect ventilation system
- Can be worn over any prescription spectacles thanks to its spherical lens
- Category III° PPE



**620.02.00.00**  
 Frame: blue  
 Field of use: 3 4 9  
 Lens: clear  
**UDC**

GOGGLES

## Applied technologies

Perfect example of technology applied to the safety field 620 goggle is equipped with a soft TPR structure that fits perfectly every face ensuring comfort and protection even at extreme temperatures. The spherical lens prevents even the slightest fogging thanks to high-performance anti-fog system UDC combined with indirect ventilation with 6 holes.



## Clean room goggle

Protective masks for use in rooms with controlled contaminations (sterile and clean rooms) and working in aseptic conditions, i.e. chemical-pharmaceutical, electronic industries or hospitals laboratories. Univet Clean Room goggles are developed to support multiple sterilization cycles with clean steam or with gamma and beta rays at 25kGy without perceptible alterations. The careful design allows a long time use and maximum transpiration, providing large field of view and use over all prescription glasses.

# 611

# CLEAN ROOM

 128g



- Sterilizable in autoclave with steam and with gamma and beta radiations
- The special material of the frame remains stable even after several cycles of sterilization
- Extra-wide elastic strap
- New version with indirect ventilation system
- Panoramic vented goggle with 2 mm polycarbonate lens
- Frame, lens and elastic strap made of anallergenic material
- RX insert available

### REFERENCE PARAMETERS

Lens	VLT = 85.80%
Elastic band	$\Delta l$ = 73.3%

VLT= Visible light transmittance  
 $\Delta l$  = Elongation%

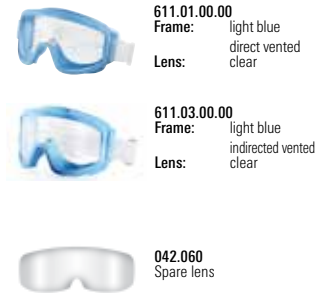

## Sterilization test performances

### GAMMA RAY radiation with 25 kGy

#### LIFE CYCLE

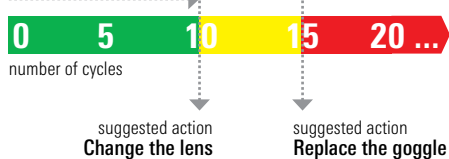

Mask elements	Number of cycles			
	0÷5	5÷10	10÷15	15÷20
Frame	No change in shape occurred	No change in shape occurred	No change in shape occurred	No change in shape occurred
Lens	VLT = 79.88% The lens became light yellow	VLT = 66.76% The lens became yellow	VLT = 62.09% The lens became yellow	VLT = 42.16% The lens became yellow
Elastic band	$\Delta l$ = 33.3%	$\Delta l$ = 18.3%	$\Delta l$ = 12.1%	$\Delta l$ = 8.7%
Buckle	No change in shape occurred	No change in shape occurred	No change in shape occurred	No change in shape occurred

### BETA RAY radiation with 25 kGy

#### LIFE CYCLE

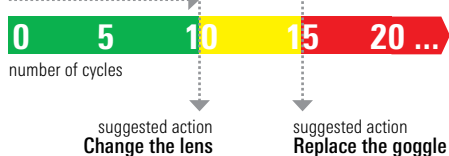

Mask elements	Number of cycles			
	0÷5	5÷10	10÷15	15÷20
Frame	No change in shape occurred	No change in shape occurred	No change in shape occurred	No change in shape occurred
Lens	VLT = 73.48% The lens became light yellow	VLT = 62.93% The lens became yellow	VLT = 56.66% The lens became yellow	VLT = 30.03% The lens became yellow
Elastic band	$\Delta l$ = 28.3%	$\Delta l$ = 17.3%	$\Delta l$ = 10.3%	$\Delta l$ = 7.3%
Buckle	No change in shape occurred	No change in shape occurred	No change in shape occurred	No change in shape occurred

### Sterilization with STEAM 121°C for 30min in 1 ATM

#### LIFE CYCLE



Mask elements	Number of cycles		
	0÷20	20÷30	30÷40
Frame	No change in shape occurred	No change in shape occurred	The frame hardened
Lens	VLT = 82.53%	VLT = 82.30%	VLT = 81.40%
Elastic band	$\Delta l$ = 63.3%	$\Delta l$ = 61.2%	$\Delta l$ = 58.3%
Buckle	No change in shape occurred	No change in shape occurred	No change in shape occurred

# 619

## CLEAN ROOM

92g



- Sterilizable in autoclave with steam and with gamma and beta radiations
- Sophisticated lower indirect ventilation system prevents the release of particulate
- The spherical lens makes the model fully overspec to prescription glasses
- Wide, fully adjustable silicone headband

REFERENCE PARAMETERS

Lens	VLT = 87.40%
Elastic band	$\Delta l$ = 60.0%

VLT= Visible light transmittance  
 $\Delta l$  = Elongation%



619.04.22.10  
 Frame: light blue  
 Lens: clear



042.085  
 Spare lens

### Sterilization test performances

#### GAMMA RAY radiation with 25 kGy

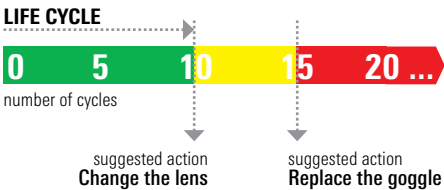

Mask elements	Number of cycles			
	0÷5	5÷10	10÷15	15÷20
Frame	No change in shape occurred	No change in shape occurred	No change in shape occurred	No change in shape occurred
Lens	VLT = 74.88% The lens became light yellow	VLT = 68.76% The lens became yellow	VLT = 62.81% The lens became yellow	VLT = 56.84% The lens became yellow
Elastic band	$\Delta l$ = 40.0%	$\Delta l$ = 18.3%	$\Delta l$ = 13.3%	$\Delta l$ = 10.0%
Buckle	No change in shape occurred	No change in shape occurred	No change in shape occurred	No change in shape occurred

#### BETA RAY radiation with 25 kGy

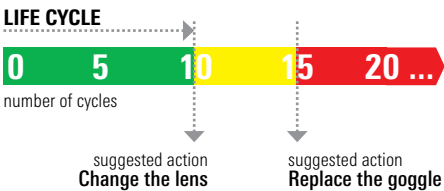

Mask elements	Number of cycles			
	0÷5	5÷10	10÷15	15÷20
Frame	No change in shape occurred	No change in shape occurred	No change in shape occurred	No change in shape occurred
Lens	VLT = 82.62% The lens became light yellow	VLT = 68.80% The lens became yellow	VLT = 65.97% The lens became yellow	VLT = 53.72% The lens became yellow
Elastic band	$\Delta l$ = 46.6%	$\Delta l$ = 21.6%	$\Delta l$ = 16.6%	$\Delta l$ = 14.3%
Buckle	No change in shape occurred	No change in shape occurred	No change in shape occurred	No change in shape occurred

#### Sterilization with STEAM 121°C for 30min in 1 ATM

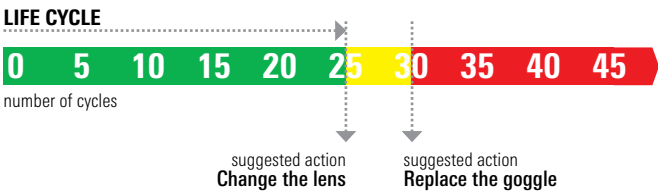

Mask elements	Number of cycles		
	0÷20	20÷30	30÷40
Frame	No change in shape occurred	No change in shape occurred	The frame hardened
Lens	VLT = 86.2%	VLT = 85.8%	VLT = 84.3%
Elastic band	$\Delta l$ = 54.8%	$\Delta l$ = 50.2%	$\Delta l$ = 42.7%
Buckle	No change in shape occurred	No change in shape occurred	No change in shape occurred

GOGGLES

# FACE SHIELDS

For certain applications the protection provided by normal eyewear may not be sufficient: in addition to the eyes is also necessary to protect the entire face. Univet range of visors has a coverage area able to protect the whole face from impacts, drops and sprays. Specific activities expose the eyes and face of the operators at various risk; Univet visors are certified according to requirements 3 (droplets and splashes of liquids), 8 (electric arc caused by short circuit) and 9 (molten metals and hot solids) in accordance with EN166 European standard.









- Repairs the whole face and eyes
- Protects against drops and sprays
- Specific version for protection against electric arc
- Fully OTG
- Wide range of screens for specific uses

	<b>607.01.00.22</b> clear polycarbonate (395x200x1 mm)		<b>607.A7.00.00</b> clear polycarbonate (395x240x2 mm) Field of use: 8 9
	<b>607.01.00.30</b> clear acetate (395x230x1 mm)		<b>607.A7.01.00</b> clear polycarbonate (395x240x2 mm) Field of use: 8 9 
	<b>607.01.00.34</b> clear (493x254x1 mm)		<b>607.A9.11.00</b> clear gold mirrored (395x240x2 mm) Field of use: 9 
	<b>607.Z0.00.01</b> blue Field of use: 9		<b>607.A9.11.30</b> green IR3 gold mirrored (395x240x2 mm) Field of use: 9 
	<b>607.Z0.00.02</b> clear Field of use: 9		<b>607.A9.11.50</b> green IR5 gold mirrored (395x240x2 mm) Field of use: 9 
	<b>607.01.00.32</b> steel face shield for brush-cutting (305x194 mm)		<b>607.A0.11.50</b> green IR5 gold mirrored (395x240x2 mm) Field of use: 9 
	<b>607.01.00.31</b> steel face shield for brush-cutting (380x194 mm)		<b>607.A9.00.47</b> UVR (395x240x2 mm) 

## Modularity:

The safety visors are available in multiple shades, materials and sizes to address each specific needs. By assembling helmets, joints and visors with various characteristics highly customized products, targeted at different security needs are obtained.



605.04.00.00



605.01.00.00



606.02.00.00



606.05.00.00

CODE	SIZE (mm)	MATERIAL	SHADE	PROTECTION AGAINST
607.01.00.22	395x200x1	Polycarbonate	Clear	Droplets and splashes, mechanical impacts
607.A7.00.00	395x240x2	Injected polycarbonate	Clear	UV radiation, droplets and splashes, mechanical <b>re-sistance A</b> , molten metals and hot solids, electric arc caused by short circuit, Category III° PPE
607.A7.01.00	395x240x2	Injected polycarbonate	Clear	UV radiation, droplets and splashes, mechanical impacts, molten metals and hot solids, <b>electric arc caused by short circuit</b> , superficial scratches (K marking), Category III° PPE
607.01.00.30	395x230x1	Acetate	Clear	Droplets and splashes, <b>chemical agents</b>
607.01.00.34	493x264x1	Technopolymer	Clear	Droplets and splashes, <b>chemical agents</b> (hydrofluoric acid)
607.A9.11.00	395x240x2	Injected polycarbonate	Clear gold mirrored	<b>Infrared radiation (R marking)</b> , radiant heating, molten metals and hot solids, mechanical impacts, Category III° PPE
607.A9.11.30	395x240x2	Injected polycarbonate	Green 3 gold mirrored	<b>Infrared radiation</b> , radiant heating, welding processes, molten metals and hot solids, mechanical impacts, Category III° PPE
607.A0.11.50	395x240x2	Injected polycarbonate	Green 5 gold mirrored	<b>Infrared radiation</b> , radiant heating, welding processes, molten metals and hot solids, mechanical impacts, Category III° PPE
607.A9.00.50	395x240x2	Injected polycarbonate	Green 5	<b>Welding processes</b> (flame cutting – welder’s aid – and oxyacetylene welding), molten metals and hot solids, mechanical impacts, Category III° PPE
607.A9.00.47	395x240x2	Injected polycarbonate	UVR	<b>Artificial optical radiations</b> , molten metals and hot solids, mechanical impacts, Category III° PPE
607.Z0.00.01	620x235x3	Thermoformed technopolymer	Bluee	Harmful optical radiations during special works in foundries, cement factories, glassworks, radiant heating, molten metals and hot solids
607.Z0.00.02	620x235x3	Thermoformed technopolymer	Clear	Radiant heating with wide coverage area, molten metals and hot solids
607.01.00.32	305x194	Wire mesh		Mechanical impacts during brushcutting
607.01.00.31	380x194	Wire mesh		Mechanical impacts during brushcutting

# 605



- Ergonomic headgear made of anallergic material
- Interchangeable front foam sweatband
- Upper band for height adjustment of the cap
- Adjustment of the head circumference by rack (53 to 61 cm)
- 90° flip-up through friction
- Version available free of exposed metal parts for protection against electric arc (605.04.00.00)



**605.01.00.00**  
Frame: yellow  
Field of use: 3



**605.04.00.00**  
Frame: blue  
Field of use: 3 8 9

# 606



**NEXXT**  

- Universal joint made of anodized aluminium or plastic
- Sealing system with spring makes the device stable and highly adaptable
- 90° flip-up with two clicks
- **Available version designed for use with safety helmet and ear muffs (606.05.00.00)**
- Version available free of exposed metal parts for protection against electric arc (606.04.00.00)



**606.02.00.00**  
Frame: black  
Field of use: 3



**606.04.00.00**  
Frame: blue  
Field of use: 3 8 9



**606.05.00.00**  
Frame: aluminium  
Field of use: 3 9

# 699



- Interchangeable front foam sweatband
- Upper band for height adjustment of the cap
- Adjustment of the head circumference by elastic band
- 1mm polycarbonate 90° flip-up visor
- It can be worn over eyewear and respirators
- Replaceable polycarbonate chin guard



**699.00.00.00**  
Frame: headgear with face shield and chin guard  
Field of use: 3



**699.99.00.00**  
Lens: face shield



**699.99.00.01**  
Lens: chin guard

# WELDING - IR

The industrial processes requiring very high temperatures, as well as cutting and welding operations, generate dangerous electromagnetic radiation.

Univet offers one of the most comprehensive range of products for welding and infrared radiation on the market. The availability of different combinations of lens shades, materials and type of devices allows to find the best solution to each workplace.



## Artificial Optical Radiation

Industrial processes that require high temperatures, as well as cutting and welding operations, generate hazardous electromagnetic radiations.

A continued exposure to the light emitted during these processes may in the long term result in serious injury to the eyes.

The danger of this radiation is increased by the fact that they are invisible to the human eye as they fall in the range of UV and IR.

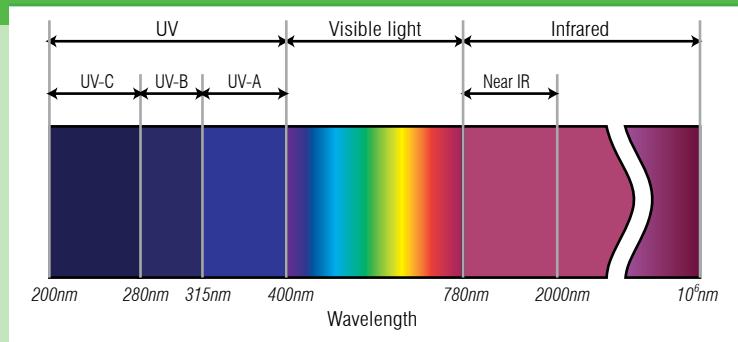

# 5X3

31 g



- Exclusive UDC coating
- Lens with FLD (Floating Lens Design) technology
- Extended 9 base wraparound lens, provides extra coverage around the eyes
- The spectacle fits the face without adjustments

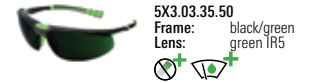

# 5X7

37 g

**softpad**  
technology



- The ultimate OTG to prescription spectacles
- The careful design of the frame prevents the overlapping of the temples for an absolute comfort
- SoftPad technology
- Adjustment of temples in length





# 5X9

52 g (glass version) / 35 g (polycarbonate version)



**SoftPad**  
technology



- Integrated side shields with ventilation system
- Adjustable temples with SoftPad technology
- Protective filters available on 90°-180° flip-up system



5X9R.00.17  
Flip: green IR1.7

5X9R.00.47  
Flip: UVR



5X9R.00.50  
Flip: green IR5



5X9R.20.42  
Flip: blue IR4-2 glass

5X9R.00.30  
Flip: green IR3

5X9R.00.60  
Flip: green IR6

5X9R.20.Y2  
Flip: blue didymium glass

5X9R.00.40  
Flip: green IR4

5X9R.00.70  
Flip: green IR7

5X9R.20.Y3  
Flip: blue IR4-5 glass

# 511



39 g



- Adjustment of temples in length and inclination
- Built-in side shields
- Frame made of anallergic material



511.03.03.03  
Frame: black  
Lens: green IR3



511.03.03.05  
Frame: black  
Lens: green IR5

# 539



29 g



- Built-in vented side shields
- Soft terminal tips eliminate local pressure and increase wearability
- Adjustment of temples in length and inclination



539.00.02.17  
Frame: black  
Lens: UVR



539.00.02.30  
Frame: black  
Lens: green IR3



539.00.02.17  
Frame: black  
Lens: green IR1.7



539.00.02.50  
Frame: black  
Lens: green IR5

# 540

 78g



- Safety goggles with two 50mm-diameter lenses
- Highly resistant nylon frame for added comfort with flip-up and side shields
- Available with fixed polycarbonate or flip-up adiacinic glass lenses



**540.00.01.07**  
 Frame: grey  
 Lens: blue IR4-5



**540.00.01.50**  
 Frame: grey  
 Lens: green IR5

# 566

 54g (glass version) / 36g (polycarbonate version)



- Two-lens eyewear equipped with tilting vented side shields
- Interchangeable lenses available
- Central screw for quick lens replacement

### GLASS



**566.01.00.50**  
 Frame: black  
 Lens: green IR5



**137.00.33**  
 spare lens glass

### POLYCARBONATE



**566.00.00.50**  
 Frame: black  
 Lens: green IR5



**137.00.35**  
 spare lens polycarbonate

# 567

 46g



- Two-lens eyewear equipped with tilting vented side shields
- Central screw for quick lens replacement



**567.00.00.50**  
 Frame: black  
 Lens: green IR5 glass

# 601

 118g



- Wide field of vision
- Indirect ventilation system
- Wide elastic band made of anallergic fabric



**601.02.06.50**  
 Frame: smoke  
 Field of use: 3 4 9  
 Lens: green IR5



# 603

 138 g (glass version) / 145 g (polycarbonate version)



- Elastic fabric headband
- Outer 90° flip-up support welding filters (diameter 50 mm)
- Indirect ventilation with four valves
- Economical version with glass lenses (603.03.00.50)



**603.01.00.50**  
 Frame: green  
 Lens: green IR5 polycarbonate



**603.03.00.50**  
 Frame: green  
 Lens: green IR5 glass

# 604

 78g



- Ultra-light frame with double cup and side ventilation valves
- Nose pad adjustment with chain
- Double polycarbonate lens available in clear anti-splinter glass and in green 5 diameter 50 mm
- Lenses are easily replaceable by ring nuts system



**604.01.00.50**  
 Frame: black  
 Lens: green IR5 glass



- Repairs the whole face and eyes
- Protects against drops and sprays
- Specific version for protection against electric arc
- Fully OTG
- Wide range of screens for specific uses



**607.A9.11.00**  
clear gold mirrored  
(395x240x2 mm)  
Field of use: 9



**607.A9.11.50**  
green IR 5 gold mirrored  
(395x240x2 mm)  
Field of use: 9



**607.A9.11.30**  
green IR3 gold mirrored  
(395x240x2 mm)  
Field of use: 9



**607.A0.00.50**  
green IR5  
(395x240x2 mm)  
Field of use: 9

# 608



- Welders' faceshield made of black fibre with handle (608.01.00.00)
- Welding helmet with flip-up system (608.02.00.00)
- Window size 75x98 mm, filters available separately



**608.01.00.00**  
Frame: black



**608.02.00.00**  
Frame: black

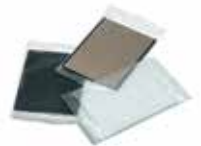

**041511**  
Lens: clear glass

**041513**  
Lens: green IR10

**1063.1**  
Support for flip-up glass  
Frame: black

**041512**  
Lens: green IR9

**041514**  
Lens: green IR11

# 608 REX



- Welding helmet with active filter and LCD screen
- Protection against UV and infrared rays and visible light (EN175 and EN379 standards compliant)
- Micrometric adjustment of the head circumference
- Available fixed-DIN (DIN 11) or potentiometer (DIN 9/13) versions



**608.04.00.00**  
Frame: blue  
Visor: DIN fix



**608.04.00.10**  
Frame: red  
Visor: potentiometer

# 609



- 90° flip-up steel mesh with window for glass filter insertion
- Universal support with knob for helmet
- Interchangeable filters (60x120mm rectangular or round 50mm diameter)



**609.04.00.15**  
Frame: steel  
Lens: blue IR4-5



**609.04.00.16**  
Frame: steel  
Lens: blue IR4-5



**609.04.00.17**  
Frame: steel  
Lens: blue IR4-5



**609.04.00.19**  
Frame: steel  
Lens: blue IR4-5



**02.21.29**  
Lens: glass blue IR4-5  
diam. 50 mm



**04.15.20**  
Lens: glass blue IR4-5  
60x120 mm



**04.16.30**  
Lens: glass blue IR4-6  
60x120 mm



**04.16.32**  
Lens: glass blue IR4-7  
60x120 mm



**04.16.33**  
Lens: glass blue IR4-8  
60x120 mm



**04.15.30**  
Lens: glass green IR5  
60x120 mm

# 618

 **64 g** (glass version) / **57 g** (polycarbonate version)



- Welding protective goggle in soft and heat resistant material
- Mineral glass lenses with  $\varnothing$  50 mm
- Elastic fabric headband guarantees an excellent wearability
- Soft frontal allows a simple and rapid replacement of the lenses and good ventilation



**618.01.06.00**  
Frame: black  
Lens: clear glass



**618.01.06.50**  
Frame: black  
Lens: green IR5 glass



glass lens 50  $\varnothing$  mm



**02.21.18**  
Lens: clear glass



**02.21.23**  
Lens: green IR5 glass



**02.21.27**  
Lens: clear  
polycarbonate



**02.21.29**  
Lens: blue IR4-5 glass



# ACCESSORIES



Cotton neck cord  
Cod. 023345



Univet neck cord with buckle  
Cod. 023346



Cotton neck cord with buckle  
Cod. 4PA114--ASSEMB-



Led  
Cod. LD90100



Microfiber pouch  
Cod. 2300072



Case with zip  
Cod. 2300062



Rigid case with zip  
Cod. 3AT029



Goggle case  
Cod. 3AT025



Rigid case with zip  
Cod. 3AT030



Univet Cleaning station  
Cod. 3QL002-



Univet cloth  
Cod. 3PA225



Anti-fog cleaner  
Cod. 3QL001



Univet cleaning tissue (pack of 24pcs)  
Cod. 3QL003-



cod. 2314000  
Univet corner  
6 positions for eyewear, 2 for goggle



cod. 2315000  
Univet display  
4 positions for eyewear, 1 for goggle



cod. 2316000  
Univet carton display  
5 positions for eyewear



cod. 3AT036-  
Univet Smartbox  
4 positions for eyewear, 1 for goggle  
390x205xH100 mm

## Customisation

Customisation is the most effective way to stand out on the market.

Thanks to the dynamism and flexibility of the production department, Univet is able to offer each kind of customisation according to the guidelines of the individual client: from the customisation of the single product to the completion of turnkey projects.

### QUICK CUSTOMISATION

The easier way to get a customised product.

The right choice for small quantities (250 pcs) and fast delivery.

### HIGH VOLUMES CUSTOMISATION

The solution for full customisation, designed for big quantity supplying (4500 pcs).

- Indelible laser-engraved personalisation
- Pad printed customisation with one or two colours
- Pad printed or embroidered personalisation on elastic headbands
- Customised packaging

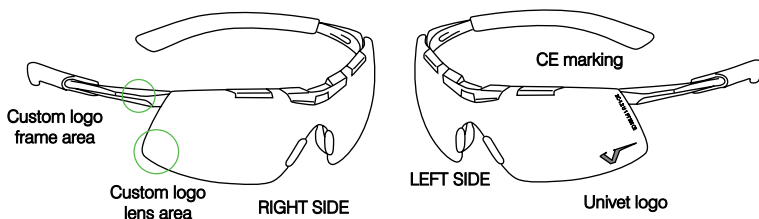



## Very Univet People

VUP members are part of an exclusive group to which we devote special attention. To each one are guaranteed constantly updated trainings on Univet technologies, products and the main safety regulations, a technical consulting service and a dedicated product specialist. We coordinate and support with qualified professionals special events developed on the needs of each distributor and its customers. The VUP members are selected to spread Univet experience, made of passion, technology and expertise and of Very Univet People.

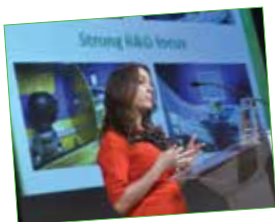

### UNIVET DAY

Specific training on eye protection by qualified personnel: regulations, applications, types of risk and products. Dedicated trainings for the sales staff and for end users.



### EXCLUSIVE EVENTS

In the company are organized exclusive events dedicated to the VUP members with updates on products and technologies, business meetings and great fun.



### PRODUCT SPECIALIST

A professional specialised in eye protection available to the distributor for support during visits to end-customers or for special requests.



### CUSTOMER SERVICE

Univet customer service ensures rapidity and flexibility in satisfying the customer needs. We can provide professional assistance in more than ten different languages.



Univet is specialized in the design and manufacture of industrial, medical, and laser safety eyewear together with magnification systems devised for the surgical and dental sector.

Univet is the only Company in the world that can offer complete lines of magnification systems and safety eyewear in so many diversified sectors: the interaction between these sectors facilitates the development of products characterized by innovative and original solutions.

Innovative, up-to-date, and internationally recognized, Univet is a Company in constant growth; from its headquarter of over 3,000 m2 in Northern Italy it exports its products to more than sixty countries all over the world, with an export quota equalling 60% of its annual sales.



**SAFETY. PLANNING YOUR PROTECTION**

The thorough ergonomic study of frames is combined with extreme care about design for a fresh conception of comfort and style. An Italian touch of class to protect yourself.



**LASER. INNOVATION FOR SAFETY**

Univet Optical Technologies: technology intended as innovation and also as continuous research towards solutions that can meet the clients' needs and taste.



**MEDICAL. BE WELCOME TO WORK**

Each single model is designed to offer the best possible protection and vetted in its aesthetic and fitness to allow the operator to work in complete harmony with its eyewear.



**LOUPES. ITALIAN IS BETTER**

Entirely Made in Italy TTL and Flip-Up magnification systems for any operator's need. High-tech optical systems offering precision and comfort in every operation.



Univet is certified ISO 9001: 2008.



All specifications and descriptions are subject to change without notice. All rights reserved. Text, images, graphics are subject to copyright and other protective laws. The content of this publication may not be copied, distributed or modified for commercial purposes without written authorization by Univet S.r.l.



[www.univet-optic.com](http://www.univet-optic.com)

HEADQUARTER

Via Giovanni Prati, 87 25086 Rezzato (BS) Italy

[info@univet.it](mailto:info@univet.it)

+39 030 2499411 fax +39 030 2499430

UNIVET INTERNATIONAL OFFICES

[france@univet-optic.com](mailto:france@univet-optic.com)

[uk@univet-optic.com](mailto:uk@univet-optic.com)

[deutschland@univet-optic.com](mailto:deutschland@univet-optic.com)

[poland@univet-optic.com](mailto:poland@univet-optic.com)

[northamerica@univet-optic.com](mailto:northamerica@univet-optic.com)

[latinamerica@univet-optic.com](mailto:latinamerica@univet-optic.com)

[asia@univet-optic.com](mailto:asia@univet-optic.com)

Follow US

